



US009871223B2

(12) **United States Patent**
Kim et al.

(10) **Patent No.:** **US 9,871,223 B2**
(45) **Date of Patent:** ***Jan. 16, 2018**

(54) **ORGANIC LIGHT EMITTING DISPLAY DEVICE HAVING MULTIPLE FILMS**

(71) Applicant: **Samsung Display Co., Ltd.**, Yongin-si, Gyeonggi-do (KR)

(72) Inventors: **Taewoong Kim**, Yongin-si (KR);
Hyunwoo Koo, Yongin-si (KR);
Hyungsik Kim, Yongin-si (KR)

(73) Assignee: **Samsung Display Co., Ltd.**, Yongin-si (KR)

(*) Notice: Subject to any disclaimer, the term of this patent is extended or adjusted under 35 U.S.C. 154(b) by 0 days.
This patent is subject to a terminal disclaimer.

(21) Appl. No.: **15/256,688**

(22) Filed: **Sep. 5, 2016**

(65) **Prior Publication Data**

US 2016/0372706 A1 Dec. 22, 2016

Related U.S. Application Data

(63) Continuation of application No. 13/609,439, filed on Sep. 11, 2012, now Pat. No. 9,437,829.

(30) **Foreign Application Priority Data**

Mar. 22, 2012 (KR) 10-2012-0029393

(51) **Int. Cl.**

H01L 51/52 (2006.01)

H01L 51/56 (2006.01)

(Continued)

(52) **U.S. Cl.**

CPC **H01L 51/5253** (2013.01); **H01L 27/3246** (2013.01); **H01L 51/0097** (2013.01);

(Continued)

(58) **Field of Classification Search**

CPC H01L 51/50; H01L 51/56; H01L 51/0097; H01L 51/524; H01L 51/5253

See application file for complete search history.

(56) **References Cited**

U.S. PATENT DOCUMENTS

7,652,291 B2 1/2010 Koo et al.

7,875,895 B2 1/2011 Kwack et al.

(Continued)

FOREIGN PATENT DOCUMENTS

KR 10-2004-0070976 8/2004

KR 10-20050046922 5/2005

(Continued)

Primary Examiner — Benjamin Sandvik

Assistant Examiner — Damon Hillman

(74) *Attorney, Agent, or Firm* — H.C. Park & Associates, PLC

(57) **ABSTRACT**

An organic light emitting display device and a method of manufacturing the same are proposed. The organic light emitting display device includes: a first film formed of an organic material, and having first and second surfaces facing each other and a third surface perpendicular to the first and second surfaces; a second film formed on the first film to cover the second and third surfaces of the first film; an organic light emitting unit disposed on the second film; a third film disposed on the second film to cover the organic light emitting unit; and a fourth film disposed on the third film, formed of an organic material, and having fourth and fifth surfaces facing each other, wherein the fifth surface faces the third film.

8 Claims, 5 Drawing Sheets

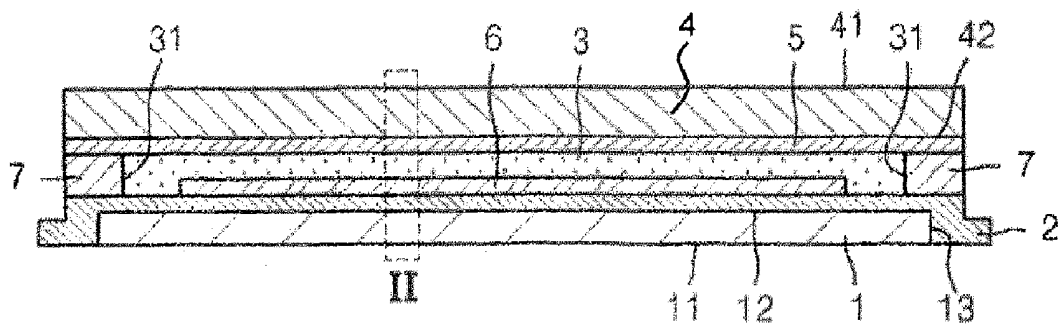

- (51) **Int. Cl.**
H01L 51/00 (2006.01)
H01L 27/32 (2006.01)
H01L 51/50 (2006.01)
- (52) **U.S. Cl.**
CPC *H01L 51/5012* (2013.01); *H01L 51/524*
(2013.01); *H01L 51/5206* (2013.01); *H01L*
51/5221 (2013.01); *H01L 51/5246* (2013.01);
H01L 51/56 (2013.01); *H01L 2251/5338*
(2013.01); *Y02E 10/549* (2013.01); *Y02P*
70/521 (2015.11)

(56) **References Cited**

U.S. PATENT DOCUMENTS

8,030,841	B2	10/2011	Kwack et al.	
8,466,456	B2	6/2013	Kim et al.	
8,481,992	B2	7/2013	Kho et al.	
8,492,754	B2	7/2013	Nishiyama et al.	
8,574,662	B2*	11/2013	Lee	H01L 51/0097 156/701
9,437,829	B2*	9/2016	Kim	H01L 51/0097
2005/0104516	A1	5/2005	Park et al.	
2008/0176476	A1	7/2008	Huang et al.	
2008/0284971	A1	11/2008	Park et al.	
2010/0181903	A1	7/2010	Kim et al.	
2011/0156062	A1*	6/2011	Kim	H01L 51/0097 257/88
2012/0068162	A1*	3/2012	Mandlik	H01L 51/5253 257/40

FOREIGN PATENT DOCUMENTS

KR	10-2010-0085347	7/2010
KR	10-0982498	9/2010

* cited by examiner

FIG. 1

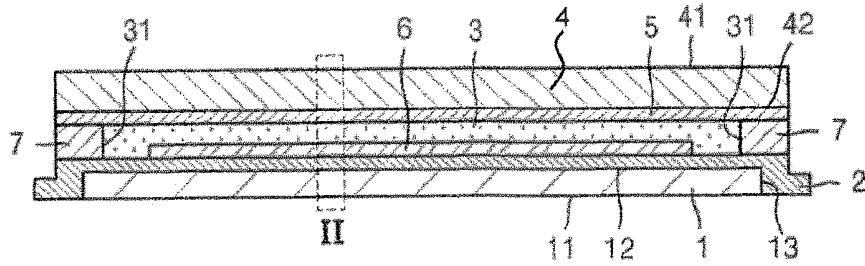

FIG. 2

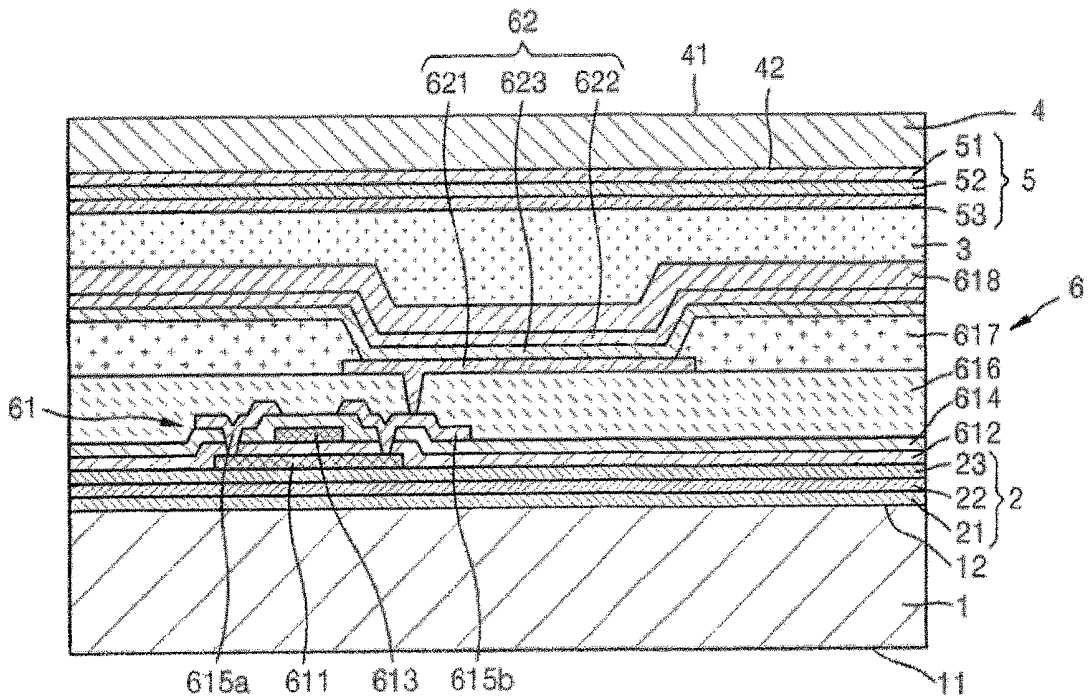

FIG. 3

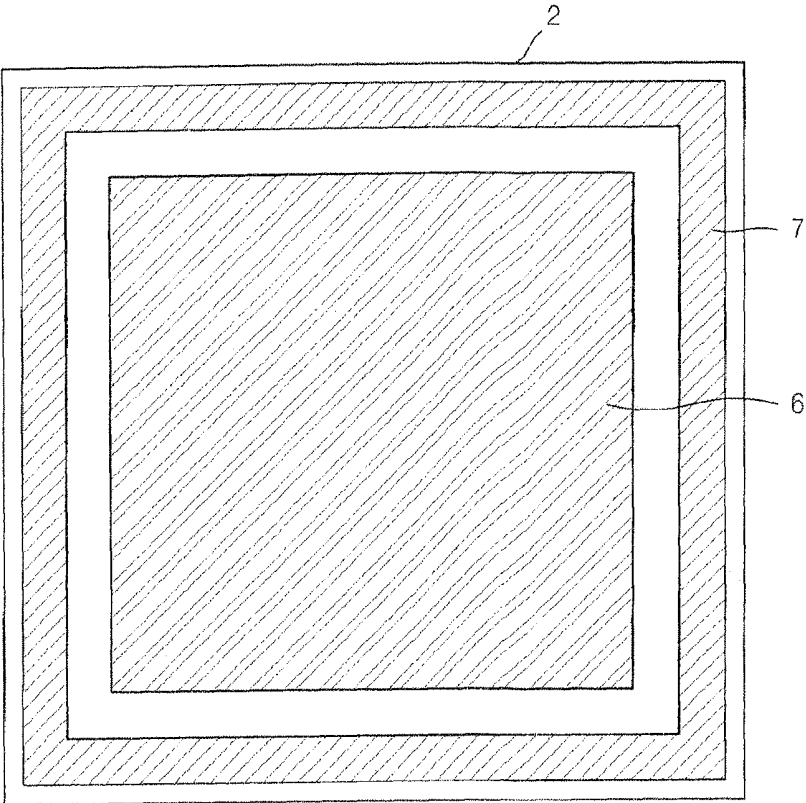

FIG. 4

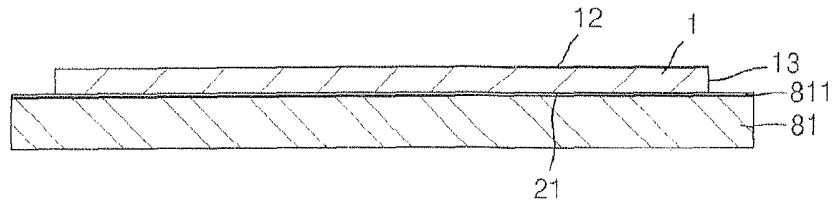

FIG. 5

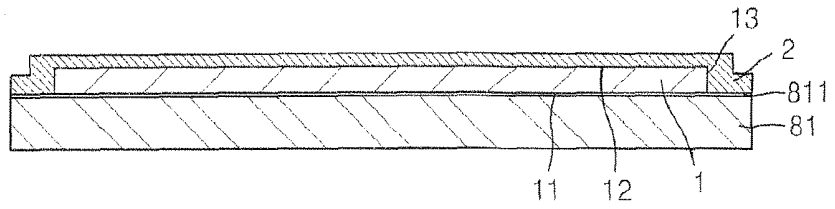

FIG. 6

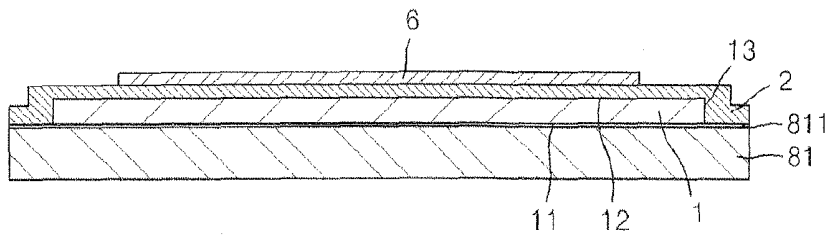

FIG. 7

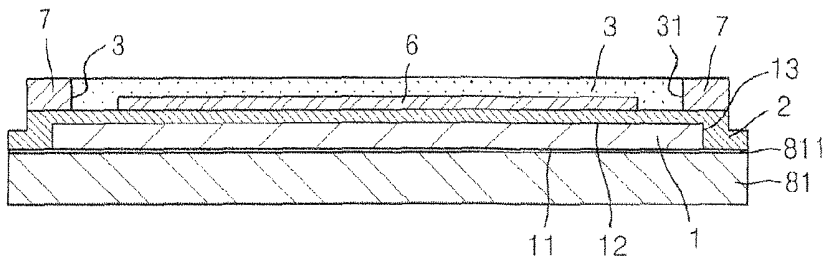

FIG. 8

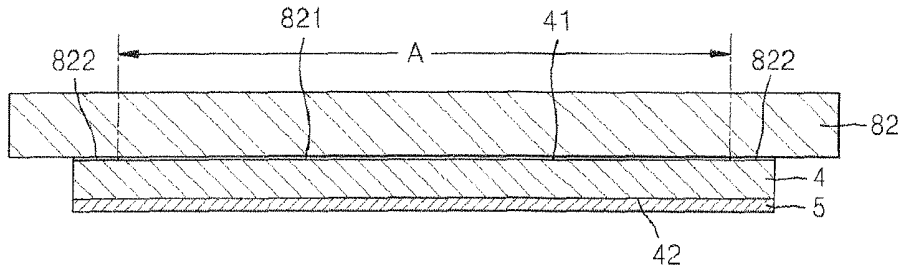

FIG. 9

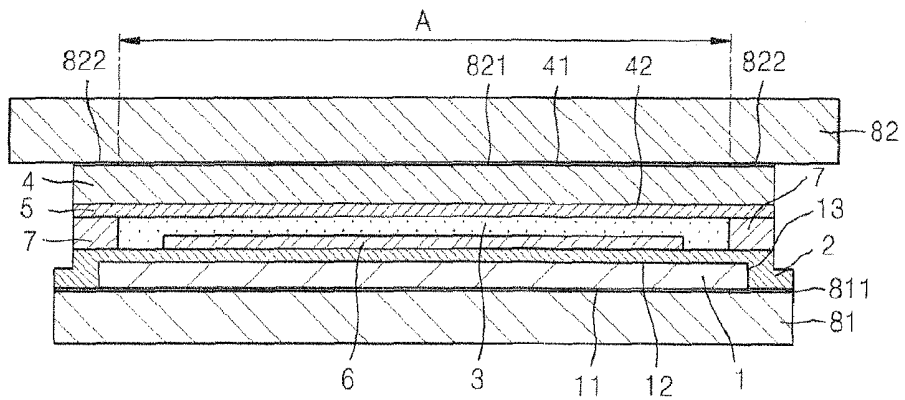

FIG. 10

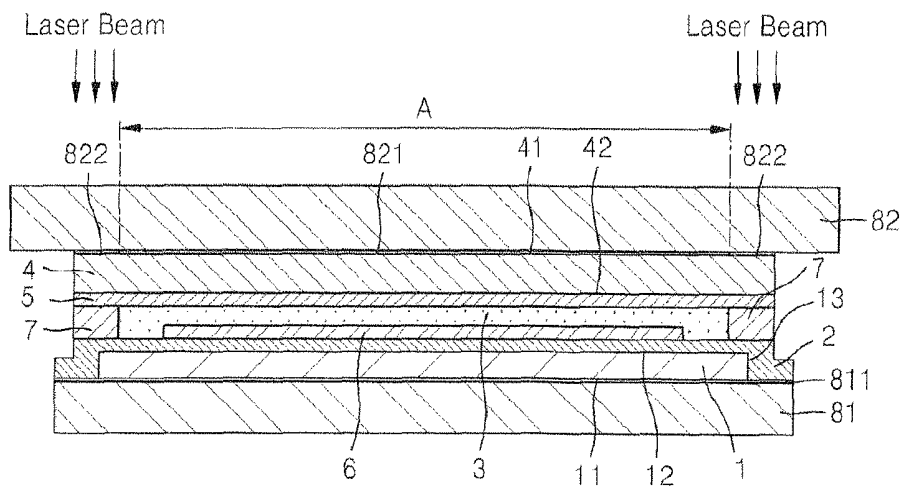

FIG. 11

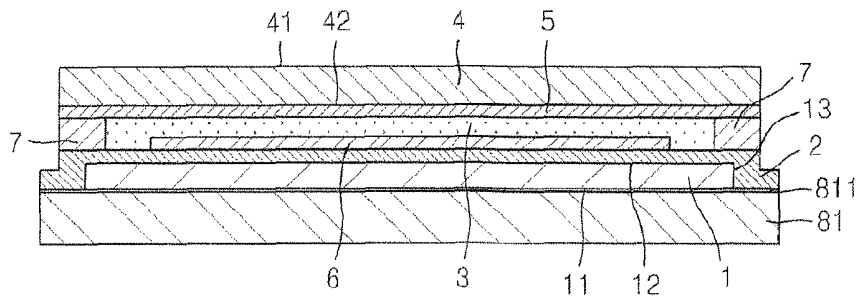

FIG. 12

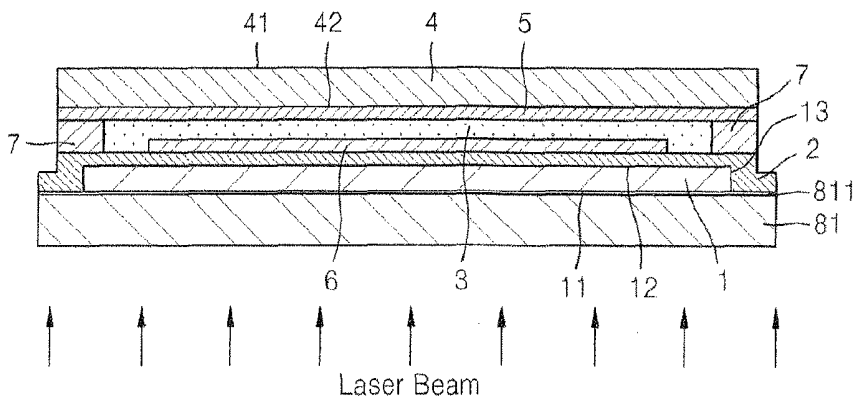
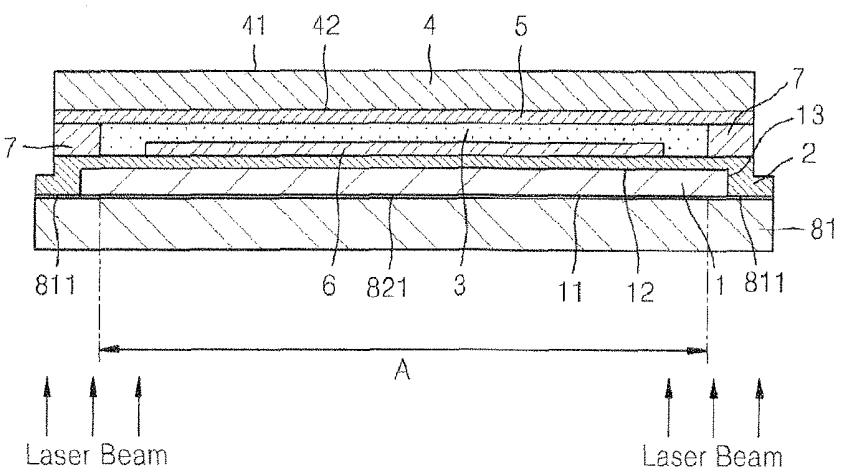

FIG. 13



ORGANIC LIGHT EMITTING DISPLAY DEVICE HAVING MULTIPLE FILMS

CROSS-REFERENCE TO RELATED PATENT APPLICATIONS AND CLAIM OF PRIORITY

This application is a continuation application of the prior application Ser. No. 13/609,439 filed in the U.S. Patent & Trademark Office on Sep. 11, 2012 and assigned to the assignee of the present invention. Furthermore, this application makes reference to, incorporates the same herein, and claims all benefits accruing under 35 U.S.C. §119 from an application earlier filed in the Korean Intellectual Property Office on 22 Mar. 2012 and there duly assigned Serial No. 10-2012-0029393.

BACKGROUND OF THE INVENTION

Field of the Invention

The present invention relates to an organic light emitting display device and a method of manufacturing the same, and more particularly, to an organic light emitting display device capable of preventing permeation of moisture, and a method of manufacturing the same.

Description of the Related Art

Since an organic light emitting display device has excellent characteristics in terms of viewing angle, contrast, response speed, and power consumption, application ranges of the organic light emitting display device are being increased from a personal portable device, such as an MP3 player or a mobile phone, to a television (TV).

Also, the organic light emitting display device has a self-emitting characteristic, and has a thin thickness and light weight unlike a liquid crystal display device, since the organic light emitting display device does not require a separate light source.

Such an organic light emitting display device may be flexible by using a plastic substrate. However, moisture permeability of the plastic substrate is too high, and thus a lifetime of the organic light emitting display device may be decreased.

SUMMARY OF THE INVENTION

According to an aspect of the present invention, there is provided an organic light emitting display device including: a first film formed of an organic material, and having first and second surfaces facing each other and a third surface perpendicular to the first and second surfaces; a second film formed on the first film to cover the second and third surfaces of the first film; an organic light emitting unit disposed on the second film; a third film disposed on the second film and covering the organic light emitting unit; and a fourth film disposed on the third film, formed of an organic material, and having fourth and fifth surfaces facing each other, wherein the fifth surface faces the third film.

The organic light emitting display device may further include a side barrier disposed on the second film and surrounding the organic light emitting unit.

The side barrier may contact at least a side surface of the third film.

The side barrier may include a hybrid polymer.

The side barrier may form a closed loop.

The organic light emitting display device may further include a fifth film disposed between the fifth surface of the fourth film and the third film. The fifth film may include an inorganic layer.

The third film may include an adhesive.

The organic light emitting display device may further include a barrier being disposed between the third film and the organic light emitting unit to cover the organic light emitting unit.

According to another aspect of the present invention, there is provided a method of manufacturing an organic light emitting display device, the method including: forming a first film on a first support substrate where the first film includes an organic material, the first film having first and second surfaces facing each other and a third surface perpendicular to the first and second surfaces such that the first surface faces the first support substrate; forming a second film on the first film to cover the second and third surfaces of the first film; forming an organic light emitting unit on the second film; forming a third film on the second film to cover the organic light emitting unit; forming a fourth film on a second support substrate where the fourth film includes an organic material, the fourth film having fourth and fifth surfaces facing each other, such that the fourth surface faces the second support substrate; combining the second support substrate to the first support substrate such that the fifth surface faces the third film; detaching the second support substrate from the fourth surface; and detaching the first support substrate from the first surface.

The method may further include forming a side barrier on the second film to surround the organic light emitting unit.

The side barrier may be formed to contact at least a side surface of the third film.

The side barrier may include a hybrid polymer.

The side barrier may form a closed loop.

The method may further include forming a fifth film on the fifth surface of the fourth film. The fifth film may include an inorganic layer.

The third film may include an adhesive.

The method may further include forming a barrier on the organic light emitting unit to cover the organic light emitting unit.

The method may further include forming a de-bonding layer on a region of the second support substrate such that the region where the de-bonding layer is formed has a wider area than a region corresponding to the organic light emitting unit, wherein the detaching of the second support substrate from the fourth surface may include applying a laser beam on a region outside the region where the de-bonding layer is formed.

The method may further include forming a de-bonding layer on a region of the first support substrate such that the region where the de-bonding layer is formed has a wider area than a region corresponding to the organic light emitting unit, wherein the detaching of the first support substrate from the first surface may include applying a laser beam on a region outside the region where the de-bonding layer is formed.

BRIEF DESCRIPTION OF THE DRAWINGS

The above and other features and advantages of the present invention will become more apparent by describing in detail exemplary embodiments thereof with reference to the attached drawings in which:

FIG. 1 is a cross-sectional view of an organic light emitting display device according to an embodiment of the present invention;

FIG. 2 is a partial magnified cross-sectional view of a region II of FIG. 1;

FIG. 3 is a plan view of the organic light emitting display device of FIG. 1;

FIGS. 4 through 12 are cross-sectional views for describing a method of manufacturing the organic light emitting display device of FIG. 1; and

FIG. 13 is a cross-sectional view illustrating another example of FIG. 12.

DETAILED DESCRIPTION OF THE INVENTION

Hereinafter, the present invention will be described more fully with reference to the accompanying drawings, in which exemplary embodiments of the invention are shown.

As used herein, the term “and/or” includes any and all combinations of one or more of the associated listed items.

FIG. 1 is a cross-sectional view of an organic light emitting display device according to an embodiment of the present invention, and FIG. 2 is a partial magnified cross-sectional view of a region II of FIG. 1.

The organic light emitting display device according to the current embodiment includes a first film 1, a second film 2, a third film 3, a fourth film 4, and an organic light emitting unit 6.

The first film 1 is formed of an organic material, and may be a transparent or opaque plastic film. For example, the first film 1 may be formed of polyimide, i.e., a high thermal resistant organic material usable even at 500° C.

The first film 1 includes a first surface 11 and a second surface 12 facing each other. Also, the first film 1 includes a third surface 13 perpendicular to the first and second surfaces 11 and 12. Referring to FIG. 1, the first surface 11 is a bottom surface, the second surface 12 is a top surface, and the third surface 13 is a side surface.

The second film 2 is formed on the first film 1 such as to cover the second and third surfaces 12 and 13 of the first film 1. Accordingly, the first surface 11 of the first film 1 is not covered by the second film 2 and is exposed. The second film 2 includes inorganic and organic materials to perform a barrier function on the first film 1.

The organic light emitting unit 6 is formed on the second film 2.

The third film 3 is disposed on the second film 2 such as to cover the organic light emitting unit 6. The third film 3 may include an adhesive, such as a pressure sensitive adhesive. Alternatively, the third film 3 may use a two-sided adhesive tape including a pressure sensitive adhesive.

Also, the fourth film 4 is disposed on the third film 3. The fourth film 4 is formed of an organic material, and may be a transparent or opaque plastic film. For example, the fourth film 4 may be formed of polyimide.

The fourth film 4 has a fourth surface 41 and a fifth surface 42 facing each other, wherein the fifth surface 42 is disposed to face the third film 3.

According to such a structure, the first film 1 constituting a lower substrate not only has the second surface 12 facing the organic light emitting unit 6 but also the third surface 13 constituting a side, which are covered by the second film 2, and thus permeation of oxygen and moisture to the first film 1 may be effectively prevented.

Meanwhile, a fifth film 5 may be further disposed between the fifth surface 42 of the fourth film 4 and the third film 3. The fifth film 5 includes inorganic and organic materials, thereby preventing moisture permeation and air permeation into the organic light emitting unit 6 through the fourth film 4.

Also, a side barrier 7 may be further formed on the second film 2 to surround the organic light emitting unit 6.

The side barrier 7 may contact a side surface 31 of the third film 3, and the side barrier 7 may prevent moisture permeation and air permeation from the side surface 31 of the third film 3 to the organic light emitting unit 6.

As shown in FIG. 3, the side barrier 7 may surround the organic light emitting unit 6 in a closed loop shape.

Also, the side barrier 7 may include a hybrid polymer, such as a hybrid organic/inorganic polymer, and in detail, an organosiloxane-based hybrid organic/inorganic polymer. The side barrier 7 may be formed of a compound containing methyltriethoxysilane and tetraethylorthosilicate.

The organic light emitting display device according to an embodiment of the present invention will now be described in detail with reference to FIG. 2.

First, the second film 2 formed on the second surface 12 of the first film 1 may have a structure, in which a layer formed of an inorganic material and a layer formed of an organic material are alternately stacked in the form of multi-layers. For example, the second film 2 may be formed on the second surface 12 of the first film 1 in a structure wherein a first layer 21, a second layer 22, and a third layer 23 are sequentially stacked on each other. Here, the first and third layers 21 and 23 may include an inorganic material, such as silicon nitride, silicon oxide, or aluminum oxide, and the second layer 22 may include an organic material, such as polyacrylate. Alternatively, the first and third layers 21 and 23 may include an organic material, and the second layer 22 may include an inorganic material. Alternatively, the first through third layers 21 through 23 may be formed of different type of inorganic materials. The second film 2 may include a single or multiple inorganic material layers.

The organic light emitting unit 6 is formed on the third layer 23. The organic light emitting unit 6 includes a pixel circuit unit including a thin film transistor 61, and an organic light emitting diode 62 from which light is emitted.

According to an embodiment of the present invention referring to FIG. 2, the thin film transistor 61 is formed on the third layer 23. Although not shown, a plurality of the thin film transistors 61 may be formed in one pixel, and a capacitor (not shown) may be simultaneously formed while forming the thin film transistor 61.

The thin film transistor 61 includes a semiconductor active layer 611 formed on the third layer 23.

The semiconductor active layer 611 may be formed of amorphous or polycrystalline silicon, but is not limited thereto, and may be formed of a semiconductor oxide. For example, the semiconductor active layer 611 may be a G-I-Z-O layer or $a(\text{In}_2\text{O}_3)b(\text{Ga}_2\text{O}_3)c(\text{ZnO})$ layer, wherein a, b, and c are real numbers satisfying $a \geq 0$, $b \geq 0$, and $c > 0$.

A gate insulation film 612 is formed on the third layer 23 such as to cover the semiconductor active layer 611, and a gate electrode 613 is formed on the gate insulation film 612.

An interlayer insulation film 614 is formed on the gate insulation film 612 such as to cover the gate electrode 613, and a source electrode 615a and a drain electrode 615b may be formed on the interlayer insulation film 614 to contact the semiconductor active layer 611 through contact holes, respectively.

The structure of the thin film transistor 61 is not limited to the above, and one of various structures of a thin film transistor may be applied.

A planarization film 616 may be formed to cover the thin film transistor 61. The planarization film 616 may be a single or multiple layers wherein a top surface is planate. The

planarization film **616** may be formed of an inorganic material and/or an organic material.

A pixel electrode **621** is formed on the planarization film **616**, and the pixel electrode **621** is connected to the drain electrode **615b** of the thin film transistor **61** through a via hole formed on the planarization film **616**.

A pixel defining film **617** is formed on the planarization film **616** such as to cover edges of the pixel electrode **621**. An organic light emitting layer **623** and a counter electrode **622** are sequentially stacked on the pixel electrode **621**. The counter electrode **622** may be a common electrode through-out all pixels.

The organic light emitting layer **623** may be a low molecular or high molecular organic film. When the low molecular organic film is used, a hole injection layer (HIL), a hole transport layer (HTL), an emission layer (EML), an electron transport layer (ETL), and an electron injection layer (EIL) may be stacked on each other in a single or multiple structure, and organic materials, such as copper phthalocyanine (CuPc), N,N'-Di(naphthalene-1-yl)-N,N'-diphenyl-benzidine (NPB), or tris-8-hydroxyquinoline aluminum (Alq3), may be used. The low molecular organic film may be formed via a vacuum deposition method. Here, the HIL, the HTL, the ETL, and the HIL may be commonly applied to red, green, and blue pixels as a common layer.

The pixel electrode **621** may function as an anode, and the counter electrode **622** may function as a cathode. Of course, polarities of the pixel electrode **621** and counter electrode **622** may be changed.

In a top-emission type where an image is realized towards the counter electrode **622**, the pixel electrode **621** may be a reflective electrode and the counter electrode **622** may be a transparent electrode. Here, the pixel electrode **621** may include a reflection film formed of silver (Ag), magnesium (Mg), aluminum (Al), platinum (Pt), palladium (Pd), gold (Au), nickel (Ni), neodymium (Nd), iridium (Ir), chromium (Cr), lithium (Li), calcium (Ca), or a compound thereof, and indium tin oxide (ITO), indium zinc oxide (IZO), zinc oxide (ZnO), or indium oxide (In₂O₃), which have a high work function. Also, the counter electrode **622** may be a thin film formed of a metal having a low work function, such as Ag, Mg, Al, Pt, Pd, Au, Ni, Nd, Ir, Cr, Li, or Ca, so as to be a semi-transmission reflective film.

In a bottom-emission type wherein an image is realized towards the pixel electrode **621**, the pixel electrode **621** may be a transparent electrode and the counter electrode **622** may be a reflective electrode. Here, the pixel electrode **621** may include ITO, IZO, ZnO, or In₂O₃, and the counter electrode **622** may include Ag, Mg, Al, Pt, Pd, Au, Ni, Nd, Ir, Cr, Li, or Ca.

In a dual-type wherein an image is realized towards both of the pixel electrode **621** and the counter electrode **622**, the pixel electrode **621** and the counter electrode **622** may be transparent electrodes.

A barrier **618** may be formed on the counter electrode **622**. The barrier **618** may be formed of an organic material and/or an inorganic material, such as polyacrylate and/or aluminum oxide.

The third film **3** is disposed on the barrier **618**, and the fourth film **4** is disposed on the third film **3**.

The fourth film **4** may include a thermal resistant organic material, such as polyimide.

The fifth film **5** may be formed on the fifth surface **42** of the fourth film **4**. The fifth film **5** may have a structure, in which a layer formed of an inorganic material and a layer formed of an organic material are alternately stacked in the form of multi-layers. For example, the fifth film **5** may have

a structure, in which a fourth layer **51**, a fifth layer **52**, and a sixth layer **53** are sequentially stacked on the fifth surface **42** of the fourth film **4**. Here, the fourth and sixth layers **51** and **53** may be formed of an inorganic material, such as silicon nitride, silicon oxide, or aluminum oxide, and the fifth layer **52** may be formed of an organic material, such as polyacrylate. Alternatively, the fourth and sixth layers **51** and **53** may be formed of an organic material, and the fifth layer **52** may be formed of an inorganic material. Alternatively, the fourth through sixth layers **51** through **53** may be formed of different types of inorganic materials. The fourth film **4** may include a single or multiple inorganic material layers. In FIG. 2, the fifth film **5** is disposed between the third film **3** and the fourth film **4**.

Next, a method of manufacturing the organic light emitting display device will be described.

First, as shown in FIG. 4, the first film **1** is formed on a first support substrate **81**. The first support substrate **81** enables the first film **1** to be easily handled, and may be a transparent glass substrate.

The first film **1** may be formed by coating the first support substrate **81** with an organic material, and then by hardening the organic material formed on the first support substrate **81**. The first film **1** may be formed of high thermal resistant polyimide usable even at 500° C.

A first combination layer **811** may be further disposed between the first support substrate **81** and the first film **1**. As described below, the first combination layer **811** enables the first support substrate **81** and the first film **1** to be easily detached from each other upon being exposed to a laser beam. The first combination layer **811** may be formed of amorphous silicon that may generate a phase change by a laser beam, but is not limited thereto. Also, the first combination layer **811** may not be included.

When the first combination layer **811** is formed on the first support substrate **81**, the first film **1** is formed on the first combination layer **811**. Accordingly, the first surface **11** of the first film **1** contacts the first combination layer **811**.

As shown in FIG. 4, the first film **1** may have a smaller area than the first support substrate **81**.

Next, as shown in FIG. 5, the second film **2** is formed on the first support substrate **81** such as to cover the second and third surfaces **12** and **13** of the first film **1**. When the first combination layer **811** is formed on the first support substrate **81**, the second film **2** is formed on the first combination layer **811**. As shown in FIG. 2, the second film **2** may include an inorganic material layer.

Here, the inorganic material layer may be formed of an aluminum oxide film using an ALD or CVD device at a high temperature, or multiple films of silicon nitride/silicon oxide.

As such, by forming the first film **1** using high thermal resistant polyimide and forming the inorganic material layer of the second film **2** at a high temperature, a denser inorganic material layer may be formed, thereby increasing moisture and oxygen blocking characteristics of the second film **2**.

Next, as shown in FIG. 6, the organic light emitting unit **6** is formed on the second film **2**.

Then, as shown in FIG. 7, the side barrier **7** and the third film **3** are formed on the second film **2**. The third film **3** may be disposed to be surrounded by the side barrier **7**. Accordingly, the side surface **31** of the third film **3** may contact the side barrier **7**.

The side barrier **7** may include a hybrid polymer having excellent barrier characteristics, such as a hybrid organic/inorganic polymer, for example, an organosiloxane-based hybrid organic/inorganic polymer. Alternatively, the side

barrier 7 may be formed of a compound containing methyltriethoxysilane and tetraethylorthosilicate. The side barrier 7 may be hardened via heat or a laser beam.

Accordingly, the side barrier 7 may block moisture and oxygen permeation from the side surface 31 of the third film 3 including the adhesive.

When such a structure is applied to a device having a large screen area such as a television (TV), a width of the side barrier 7 may be increased due to a margin at edges of a screen, and thus barrier characteristics may be further improved.

Meanwhile, as shown in FIG. 8, a second support substrate 82 is prepared. The second support substrate 82 functions as a support for handling of the fourth film 4, and may be a transparent glass substrate.

The fourth film 4 may be formed by coating the second support substrate 82 with an organic material, and by hardening the organic material formed on the second support substrate 82.

As shown in FIG. 8, a de-bonding layer 821 is further disposed between the second support substrate 82 and the fourth film 4. The de-bonding layer 821 is formed in a region A of the second support substrate 82, wherein an area of the region A is larger than an area of a region corresponding to the organic light emitting unit 6 as described below. In the region A wherein the de-bonding layer 821 is formed, the second support substrate 82 and the fourth film 4 are not attached to each other, or are easily de-bonded without a laser beam irradiation due to the de-bonding layer 821. The de-bonding layer 821 may be formed by surface-treating the second support substrate 82.

A second combination layer 822 may be further disposed between the second support substrate 82 and the fourth film 4 outside the region A where the de-bonding layer 821 is formed. As described below, the second combination layer 822 enables the second support substrate 82 and the fourth film 4 to be easily detached from each other upon being exposed to a laser beam. The second combination layer 822 may be formed of amorphous silicon that may generate a phase change by a laser beam, but is not limited thereto. Also, the second combination layer 822 may not be included.

According to such a structure, the fourth film 4 is combined to the second support substrate 82 in a region where the second combination layer 822 is formed, and the fourth film 4 and the second support substrate 82 are detached from each other by irradiating the second combination layer 822 with a laser beam.

The fourth film 4 is formed on the second combination layer 822 and the de-bonding layer 821. Accordingly, the fourth surface 41 of the fourth film 4 contacts the second combination layer 822 and the de-bonding layer 821.

Then, the fifth film 5 is formed on the fifth surface 42 of the fourth film 4.

As shown in FIG. 2, the fifth film 5 may include an inorganic material layer.

Here, the inorganic material layer may be formed of an aluminum oxide film by using an ALD or CVD device at a high temperature, or a multiple films of silicon nitride/silicon oxide.

By forming the fourth film 4 using high thermal resistant polyimide and forming the inorganic material layer of the fifth film 5 at a high temperature, a denser inorganic material layer may be formed, thereby increasing moisture and oxygen blocking characteristics of the fifth film 5.

Next, as shown in FIG. 9, the film structure built on the second support substrate 82 and the film structure built on

the first support substrate 81 are combined to each other. Here, the fifth film 5 contacts the third film 3 and the side barrier 7, and then is pressed such that the fifth film 5 is combined to the third film 3.

Alternatively, the side barrier 7 may be formed after the third and fifth films 3 and 5 are combined to each other.

Then, as shown in FIG. 10, a laser beam is applied from outside the second support substrate 82. Here, the laser beam is applied to the second combination layer 822 outside the region A where the de-bonding layer 821 is formed. Thereby, the second support substrate 82 and the fourth film 4 are detached from each other, as shown in FIG. 11, through a phase change of the second combination layer 822. By not applying the laser beam to the region A where the de-bonding layer 821 is formed, the organic light emitting unit 6 is prevented from being exposed to the laser beam, and thus the organic light emitting unit 6 is prevented from deteriorating by the laser beam. Alternatively, the laser beam may be applied only on the second combination layer 822, and at this time, the side barrier 7 may be simultaneously hardened.

Then, as shown in FIG. 12, a laser beam is applied from outside the first support substrate 81 so that the first support substrate 81 is detached from the first and second films 1 and 2 by a phase change of the first combination layer 811.

Here, as shown in FIG. 2, since a circuit unit including the thin film transistor 61 is formed below the organic light emitting unit 6 formed on the second film 2, an adverse effect to the organic light emitting diode 62 may be reduced even if a laser beam is irradiated in general from the bottom of the first support substrate 81.

However, alternatively as shown in FIG. 13, the de-bonding layer 821 may be also formed on the first support substrate 81 in the region A, which is larger than the region corresponding to the organic light emitting unit 6, and the first combination layer 811 may be formed outside the de-bonding layer 821, thereby separating the first support substrate 81 from the first and second films 1 and 2 by applying a laser beam only to the first combination layer 811 outside the de-bonding layer 821. Here, since a laser beam is blocked from being applied to the organic light emitting unit 6, quality of the organic light emitting unit 6 may be further improved.

While the present invention has been particularly shown and described with reference to exemplary embodiments thereof, it will be understood by those of ordinary skill in the art that various changes in form and details may be made therein without departing from the spirit and scope of the present invention as defined by the following claims.

What is claimed is:

1. An organic light emitting display device comprising: a first film formed of an organic material, and having first and second surfaces facing each other and a third surface perpendicular to the first and second surfaces; a second film formed on the first film, wherein the second film is formed from electrically insulating material; an organic light emitting unit disposed on the second film, the organic light emitting unit comprising: a thin film transistor formed on the second film; a pixel electrode electrically connected to the thin film transistor; an organic light emitting layer formed on the pixel electrode; a pixel defining film covering edges of the pixel electrode; and a counter electrode formed on the organic light emitting layer;

a third film disposed on the second film and covering the organic light emitting unit; and

a fourth film disposed on the third film, formed of an organic material, and having fourth and fifth surfaces facing each other, the fifth surface facing the third film. 5

2. The organic light emitting display device of claim 1, further comprising a side barrier disposed on the second film and surrounding the organic light emitting unit.

3. The organic light emitting display device of claim 2, wherein the side barrier contacts at least a side surface of the third film. 10

4. The organic light emitting display device of claim 2, wherein the side barrier comprises a hybrid polymer.

5. The organic light emitting display device of claim 2, wherein the side barrier forms a closed loop. 15

6. The organic light emitting display device of claim 1, further comprising a fifth film disposed between the fifth surface of the fourth film and the third film, the fifth film including an inorganic layer.

7. The organic light emitting display device of claim 1, wherein the third film comprises an adhesive. 20

8. The organic light emitting display device of claim 1, further comprising a barrier being disposed between the third film and the organic light emitting unit to cover the organic light emitting unit. 25

* * * * *

专利名称(译)	具有多个膜的有机发光显示装置		
公开(公告)号	US9871223	公开(公告)日	2018-01-16
申请号	US15/256688	申请日	2016-09-05
[标]申请(专利权)人(译)	三星显示有限公司		
申请(专利权)人(译)	三星DISPLAY CO. , LTD.		
当前申请(专利权)人(译)	三星DISPLAY CO. , LTD.		
[标]发明人	KIM TAEWOONG KOO HYUNWOO KIM HYUNGSIK		
发明人	KIM, TAEWOONG KOO, HYUNWOO KIM, HYUNGSIK		
IPC分类号	H01L51/52 H01L51/56 H01L51/00 H01L51/50 H01L27/32		
CPC分类号	H01L51/5253 H01L27/3246 H01L51/0097 H01L51/5012 H01L51/524 H01L51/5221 H01L51/5246 H01L51/56 H01L51/5206 Y02P70/521 H01L2251/5338 Y02E10/549 H01L51/5203 H01L51/5237 H01L51/5262 H01L2251/50		
优先权	1020120029393 2012-03-22 KR		
其他公开文献	US20160372706A1		
外部链接	Espacenet USPTO		

摘要(译)

提出了一种有机发光显示装置及其制造方法。有机发光显示装置包括：第一膜，由有机材料形成，并具有彼此面对的第一和第二表面以及垂直于第一和第二表面的第三表面；在第一膜上形成第二膜以覆盖第一膜的第二和第三表面；有机发光单元，设置在第二膜上；第三膜设置在第二膜上以覆盖有机发光单元；第四膜设置在第三膜上，由有机材料形成，并具有彼此面对的第四和第五表面，其中第五表面面对第三膜。

